

Low Profile, High Current Power Inductors

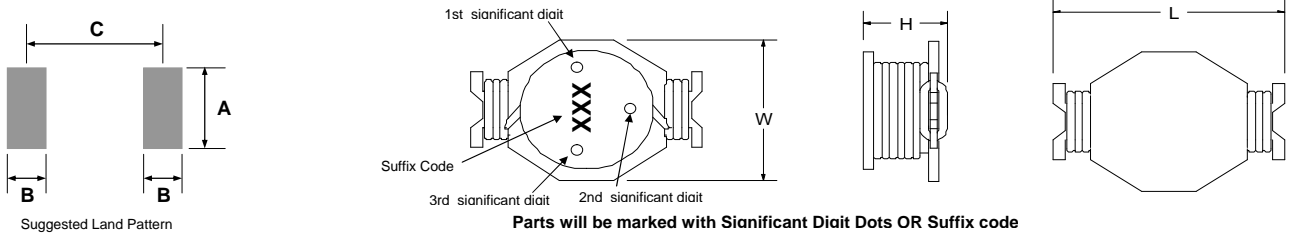

Parts will be marked with Significant Diat Dots OR Suffix code

Series Number	Maximum Dimensions			Reference Dimensions			
	Units	L	W	H	A	B	C
MGDH1	inches	0.362"	0.252"	0.197"	0.160"	0.075"	0.200"
	[mm]	[9.19]	[6.40]	[5.00]	[4.06]	[1.91]	[5.08]

Features:

- High energy storage and low resistance
- Reliable surface mounting, flat top for pick and place.
- Smaller real estate than other common inductors.
- Robust temperature deflection to prevent damage during solder reflow.
- Tape and Reel mechanical specifications available upon request.
- Operating Temperature -40°C to +85°C.
- Highly resistive core for EMI suppression applications.
- Lead Free RoHS compliant.



Terminal Plating is Hot-dipped SnAgCu
 260°C Maximum reflow temperature per J-STD020

Notes:

- Inductance measured at 100kHz and 250mVrms.
- Isat is a maximum applied AC + DC current.
- Isat current is applied to produce a typical 35% drop in nominal inductance.
- Tolerance suffix of M = ±20%.
- DCR is a maximum at 20°C.

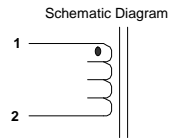

Contact CoEv for additional inductance values

Lead free Part Number	L μH	MGDH1				Tolerance Suffix ⁶
		DCR ² W	I _{SAT} ³ A	I _{RMS} ⁵		
MGDH1-00001	0.33	0.010	7.7	6.00	M	
	0.56					
	0.68					
	0.78					
	1.0					
MGDH1-00002	1.2	0.017	5.3	4.40	M	
	1.5					
MGDH1-00003	2.2	0.035	3.5	3.10	M	
	2.7					
	3.3					
	3.9					
MGDH1-00004	4.7	0.054	2.6	2.20	M	
	6.0					
	6.8					
	7.8					
MGDH1-00005	10	0.111	1.90	1.50	M	
MGDH1-00006	15	0.170	1.50	1.20	M	
MGDH1-00007	22	0.250	1.20	1.00	M	
MGDH1-00008	33	0.370	0.99	0.82	M	
MGDH1-00009	47	0.470	0.87	0.72	M	
	68					
	100					

Specifications subject to change

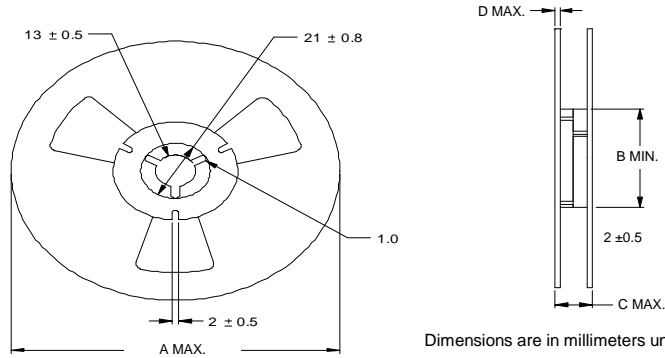

Dimensions are in millimeters unless specified.

Series Number	Reel dimensions				Reel Qty	Carton (Box) Qty.	Packaging Specification
	Units	A	B	C			
MGDH1	in.	14.17"	3.94"	0.882"	1000	6000	90-0061
	[mm]	[360]	[100.0]	[22.4]			

PACKAGING NOTE: Only pressure sensitive cover tape is to be used.

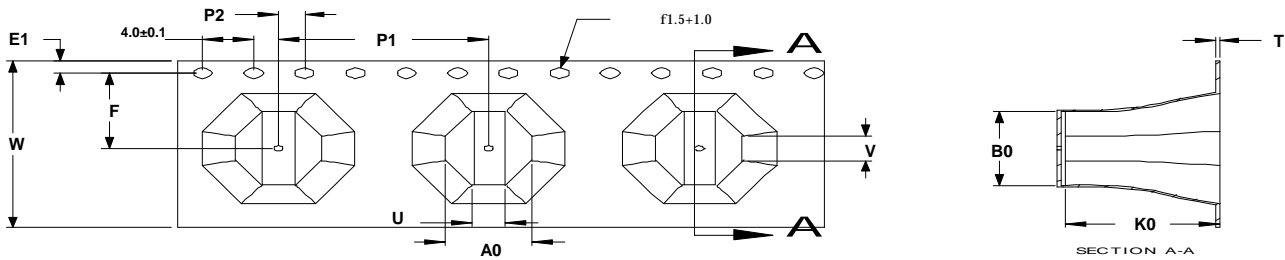
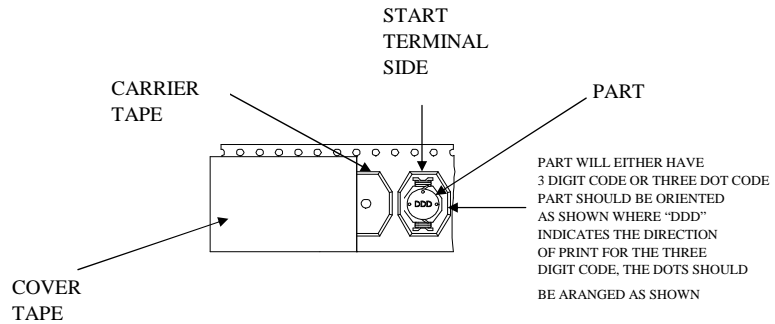

Series	A0 ± 0.1	U ± 0.1	V ± 0.1	P1 ± 0.1	P2 ± 0.1	W ± 0.3	F ± 0.1	E1 ± 0.1	B0 ± 0.1	K0 ± 0.05	T ± 0.05
MGDH1	6.65	4.70	2.90	12.00	2.00	16.00	7.50	1.75	9.45	4.70	0.35



Customer Packaging Specifications
For Print Distribution to Customers

Series	Revision
MGDH1	A0
Sheet 2 of 7	

Item	Specification	Test Method/Condition
Environmental		
Static Humidity	After exposure part remains within specified electrical parameters for L, Q and DCR.	Precondition at 25°C for 60 minutes. Expose parts to an environment of +40°C with 90 to 95% R.H. for 240 hours.
	After exposure part remains within specified electrical parameters for L, Q and DCR.	Subject parts to an environment of 85°C 85% R.H. for 168 hours. After exposure allow parts to dry for 4 hours before measurements are taken.
Temperature Cycle	After exposure part remains within specified electrical parameters for L, Q and DCR.	10 cycles (Air to Air) 1 cycle shall consist of: 30 minutes exposure to +85°C 30 minutes exposure to -40°C Allow 20 minutes transition between extremes.
Temperature Shock	After exposure part remains within specified electrical parameters for L, Q and DCR.	10 cycles (Air to Air) 1 cycle shall consist of: 30 minutes exposure to -55°C 30 minutes exposure to +125°C 15 seconds maximum transition between temperatures
General		
Storage Temperature Range	-40°C to +85°C	
Operating Temperature Range	-40°C to +85°C	
Flammability	IEC 695-2-2	Withstands needle-flame test
Other		
Vibration	After exposure part remains within specified electrical parameters for L, Q and DCR.	1 cycle of 30 minutes of the following: 5 - 7 Hz constant displacement of 0.75 inches, 5 minutes 7 - 30 Hz constant acceleration of 1.5 Gs, 10 minutes 31 - 50 Hz constant displacement of 0.33 inches, 5 minutes 50 - 500 Hz constant acceleration of 1.2 Gs, 10 minutes
Mechanical Shock	After exposure part remains within specified electrical parameters for L, Q and DCR.	MGDH1 Series - 2000 Gs per axis, 2 directions MGDH2 Series - 2000 Gs per axis, 2 directions MGDH3 Series - 2000 Gs per axis, 2 directions
Solderability	Wetting shall cover 90% minimum of each termination	Dip pads in RMA flux, 63/37 solder (Sn/Pb) at 232°C for 5 seconds ±2 seconds.
Component Adhesion (Push Test)	Component shall withstand 6 lb. push force minimum without delaminating from mounting surface.	Apply and measure force with a digital force gauge set.
Resistance to Solvent		Withstands 6 minutes of alcohol. Withstands 3 minutes forced spray Freon TMS
Chemical		
Ionic Contamination	Conductivity: pH: Chlorides: Sodium: Potassium:	11 µOhms/cm maximum 5.5 to 9 65 ppm maximum 20 ppm maximum 10 ppm maximum



RoHS Compliant

For Print Distribution to Customers	Series	Revision
	MGDH1	A0
	Sheet 3 of 7	